

APD-100

AVALANCHE PHOTODIODE DETECTOR

USER MANUAL

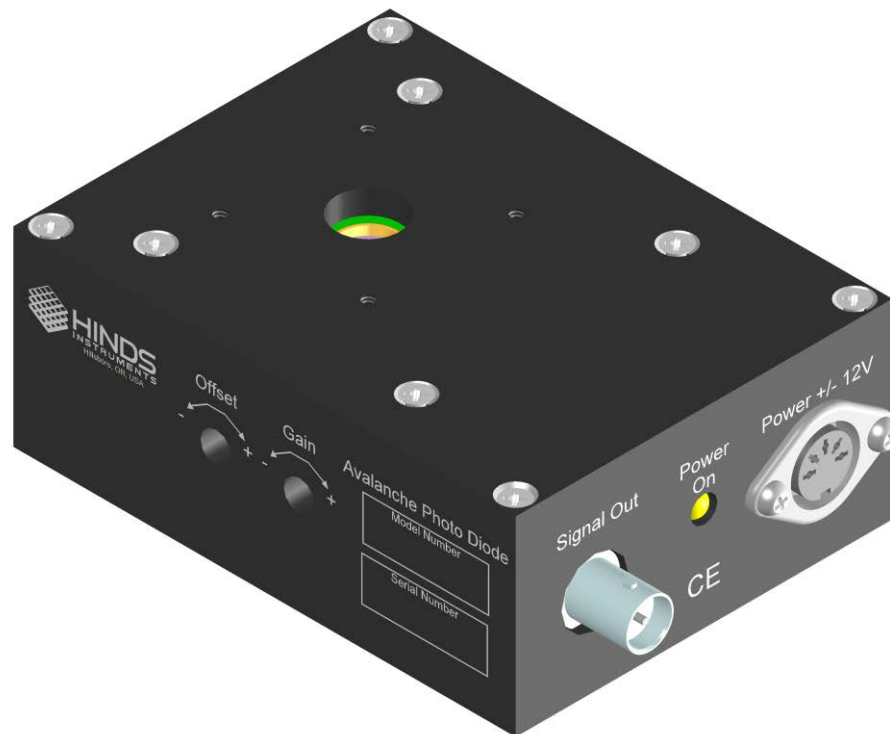

Hinds Instruments, Inc.
P/N: 020-2651-025-R UM Rev D

Copyright © 2007, 2013 by Hinds Instruments, Inc.

THIS DOCUMENT IS PROVIDED “AS IS” WITH NO WARRANTIES WHATSOEVER, INCLUDING ANY WARRANTY OF MERCHANTABILITY, FITNESS FOR ANY PARTICULAR PURPOSE, OR ANY WARRANTY OTHERWISE ARISING OUT OF ANY PROPOSAL, SPECIFICATION OR SAMPLE. All rights reserved. No part of this publication may be reproduced, stored in a retrieval system, or transmitted, in any form by any means, electronic, mechanical, by photocopying, recording, or otherwise, without the prior written permission of Hinds Instruments, Inc.

Information furnished by Hinds Instruments, Inc. is believed to be accurate and reliable; however, no responsibility is assumed by Hinds Instruments, Inc. for its use; nor for any infringements of patents or other rights of third parties which may result from its use. No license is granted by implication or otherwise under any patent rights of Hinds Instruments, Inc.

In all respects, the English version of this manual is controlling.

Exicor, Signaloc, PEMLabs, Hinds Instruments and the Hinds Instruments, Inc. graphic logo are trademarks of Hinds Instruments, Inc.

*Third-party brands and names are the property of their respective owners.

Table of Contents

Table of Contents.....	i
1 Introduction	1
APD-100 Overview	1
Accessories.....	1
SCU-100.....	1
2 APD-100 Front, Side and Top Plate Identification.....	3
APD-100 Front Plate.....	3
APD-100 Front Plate Functional Items.....	3
APD-100 Side Plate	4
APD-100 Side Plate Functional Items.....	4
APD-100 Top Plate	5
APD-100 Top Plate Functional Items.....	5
3 Initial Set-Up.....	7
Connecting the APD-100	7
4 Operating the APD-100	9
Operation.....	9
5 Troubleshooting.....	11
Troubleshooting Guide – Symptoms & Possible Remedies	11
A Specifications	13
APD-100 General	13
APD-100 Input / Output Specifications	13
APD-100 Environmental.....	14
APD-100 Approvals.....	14
Desktop Power Supply, General	14
Desktop Power Supply, Input/Output Specifications	14
Desktop Power Supply - Environmental.....	15
Desktop Power Supply Approvals	15
B User Support Information	17
Limited Warranty.....	17
Exclusions.....	17
Return for Repair Procedure	18
Packing.....	18
Include.....	18
Shipping.....	18
Send to:	18
Index	21

Introduction

APD-100 Overview

Hinds Instruments Model APD-100 Avalanche Photodiode Detectors are specifically designed for use in photoelastic modulator (PEM) based systems. They feature DC coupling, wide frequency response, and low impedance voltage output to drive signal coaxial cables.

The frequency bandwidth of the detector should be at least several times the modulator frequency. This allows an accurate display of the modulated waveform on an oscilloscope, which is useful for retardation calibration.

The buffered low-impedance voltage output enables driving the signal coaxial cable without loss of frequency bandwidth. The output is suitable for connection to an oscilloscope, a lock-in amplifier, a signal conditioner, or many other electronic instruments.

The APD-100 includes the Avalanche Photodiode Detector, post mount, and universal power supply.

Accessories

SCU-100

The SCU-100 Signal Conditioning Unit takes an input signal, as from a detector, splits the signal into its broadband AC and low-pass DC signals, amplifies these signals, then applies the amplified signals to AC and DC outputs. The SCU-100 AC output voltage can be determined using a lock-in amplifier and the DC output voltage can be measured with a digital voltmeter. The ratio of the AC to DC voltage is a necessary computation for the measurement of linear and circular dichroism.

The SCU-100 provides 8-level and 9-level amplification controls for the AC and DC gain controls, respectively.

2

APD-100 Front, Side and Top Plate Identification

APD-100 Front Plate

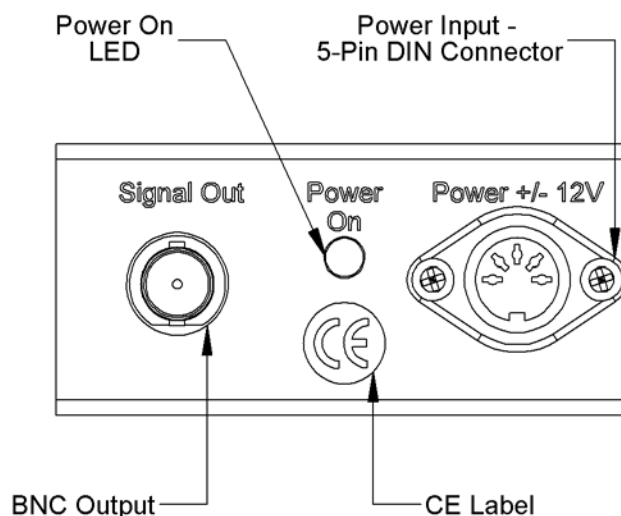

Figure 2.1: APD-100 Front Plate

APD-100 Front Plate Functional Items

Power +/- 12V: The APD-100 package includes a +/-12VDC desktop power supply that plugs into the APD-100 Power +/-12V power jack. The power supply operates from 100-250 VAC line voltage.

Signal Out: The APD-100 signal output is provided via the Signal Out BNC connector. Note that this output is intended for high impedance loads. Do not connect this output to a 50 Ohm impedance input.

Power ON: The green Power On LED will illuminate whenever +/- 12VDC power is applied to the device.

CE Label: The CE label certifies that the APD-100 complies with European Union EMC directives.

APD-100 Side Plate

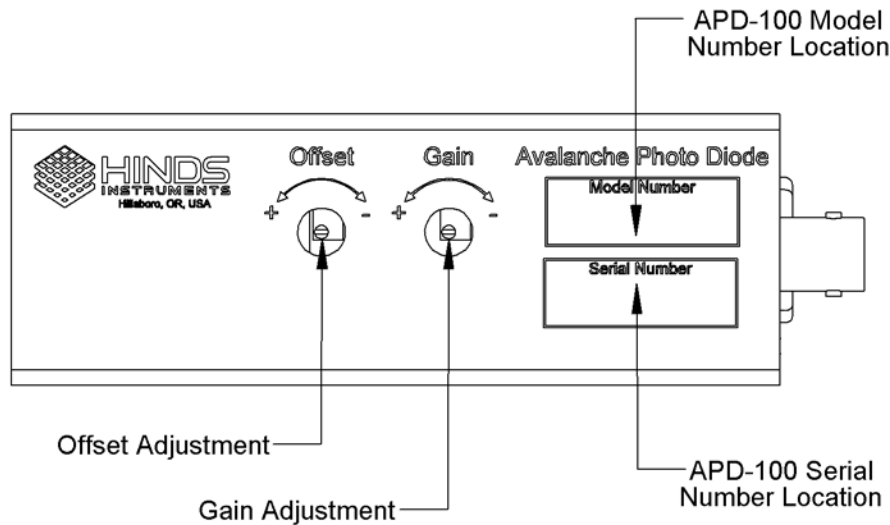

Figure 2.2: APD-100 Side Plate

APD-100 Side Plate Functional Items

Offset Adjustment: The APD-100 provides an output offset adjustment via a 12-turn potentiometer that can be used to set the output to zero volts DC. Counter-clockwise rotation of the potentiometer will lower the output offset and clockwise rotation will raise the output offset.

Note: The offset adjustment should be done after setting the gain.

Gain Adjustment: The APD-100 provides a gain adjustment via a 12-turn potentiometer that can be used to vary the gain of the device. Counter-clockwise rotation of the potentiometer will decrease the gain and clockwise rotation will increase the gain.

Model Number: This shows the type of detector purchased.

Serial Number: This shows the serial number of the detector purchased.

APD-100 Top Plate

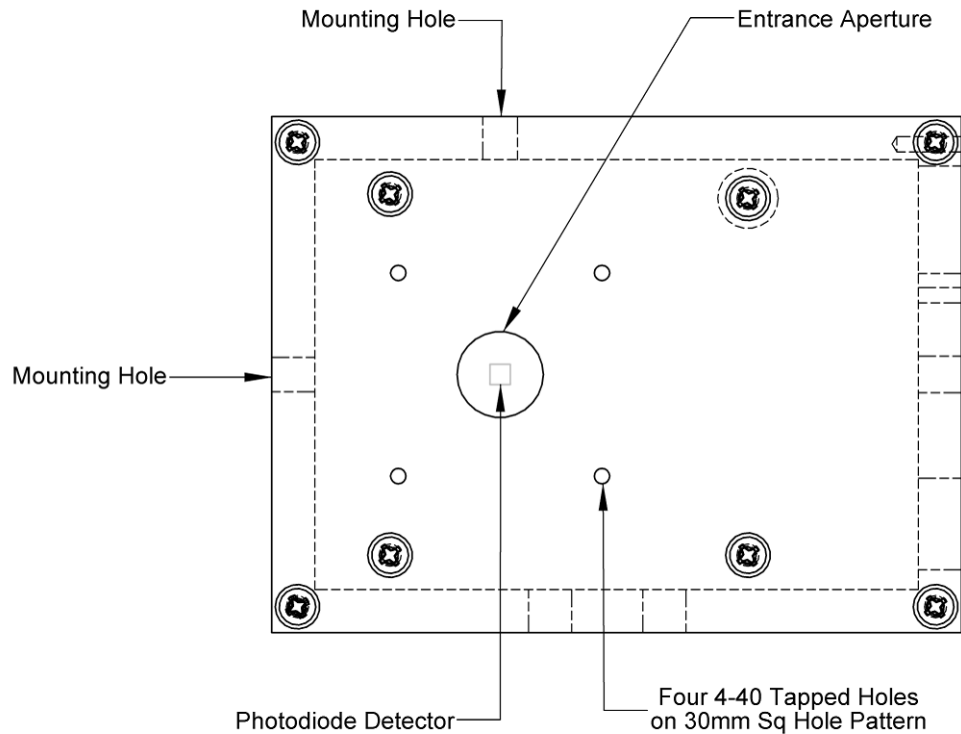

Figure 2.3: APD-100 Top Plate

APD-100 Top Plate Functional Items

Entrance Aperture and Photodiode Detector: The APD-100 photodiode detects a light source striking it via the Top Panel Entrance Aperture.

Mounting Holes: The APD-100 provides two $\frac{1}{4}$ -20 mounting holes. Each mounting hole is in-line with the center of the photodiode detector. The customer may choose whichever mounting hole is convenient to use. In addition, the APD-100 provides four 4-40 tapped holes for use in mounting optical accessories. These holes are arranged in a 30mm square hole pattern centered on the entrance aperture.

CAUTION

High voltages exist inside the APD-100

The APD-100 uses high voltages (up to 150V DC) to bias the avalanche photodiode detector. Do not disassemble the APD-100 or insert anything into the mounting holes other than $\frac{1}{4}$ -20 mounting hole screws. In addition, limit mounting hole screw length to 1/2 inch.

3

Initial Set-Up

Connecting the APD-100

The figure below shows an example setup where the APD-100 might be used. The APD-100 is connected as follows:

1. The APD-100 is placed with the light source striking the center of the photodiode via the entrance aperture.
2. The APD-100 output is connected to an oscilloscope input via a coaxial cable (not provided). Make sure the oscilloscope input is set to high impedance mode, NOT 50 OHM mode!
3. Connect the APD-100 desktop power supply to line voltage and connect the DC plug to the APD-100 +/- 12V power jack.

A DC level change should be seen on the oscilloscope (with input coupling set to DC) and a sine wave should be seen if the modulator is functioning. Blocking then unblocking the light source while watching the oscilloscope helps to confirm proper operation when detecting low intensity light sources.

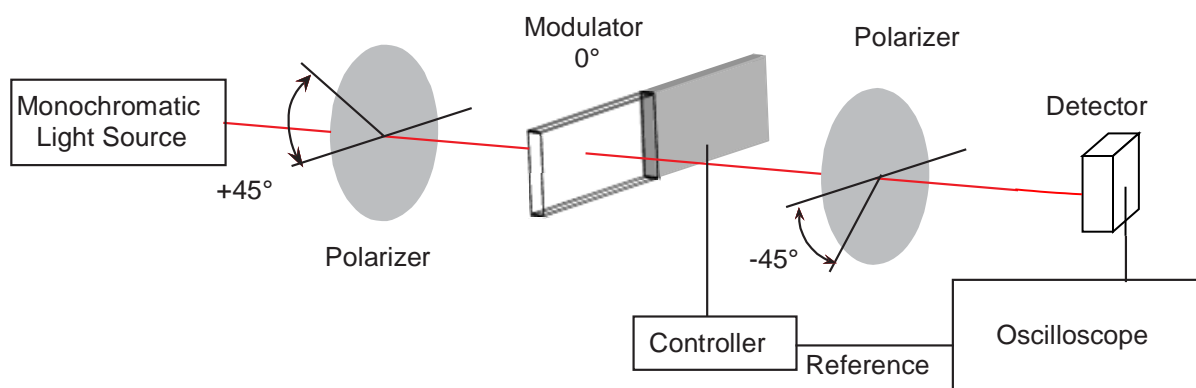

Figure 3.1: Example Setup for Detector Test

4

Operating the APD-100

Operation

The solid-state Si Avalanche Photodiode detector used in the APD-100 provides a current signal output which is proportional to the intensity of the visible light striking it. An integrated preamplifier converts this current signal to a voltage signal. An integrated amplifier provides voltage amplification and filtering and buffers the signal output.

The APD-100 provides an integrated 12-turn potentiometer for adjusting the gain. Counter-clockwise rotation of the potentiometer will decrease the gain and clockwise rotation will increase the gain. The user should be aware of the effects of saturation – wherein the linear relationship between the incident light flux and the detector output is no longer being maintained. The user should limit the maximum intensity light levels at minimum and maximum gain to 250uW and 5uW, respectively.

The APD-100 provides an integrated 12-turn potentiometer for adjusting the output offset to zero volts DC. Counter-clockwise rotation of the potentiometer will lower the output offset and clockwise rotation will raise the output offset. Total offset range is +/- 30mVDC. The output offset should be adjusted AFTER the gain has been set and with the entrance aperture covered.

The APD-100 provides two ¼-20 size post mounts for convenient mounting on an optical bench. The post mounts, each in-line with the photodiode, allow the detector to be mounted 90° about the optical axis.

The APD-100 output can be amplified and filtered using a Hinds Instruments SCU-100 Signal Conditioning Unit or connected directly to a lock-in amplifier, oscilloscope or desired instrument. The APD-100 cannot drive a 50 Ohm load, so ensure that the instrument is set to high impedance mode.

5

Troubleshooting

Troubleshooting Guide – Symptoms & Possible Remedies

Power Problems	
Symptoms No signal output from APD-100.	Possible Remedies Possible remedies The AC cord is unplugged from the wall outlet or from the desktop power supply. The desktop power supply DC plug is not fully engaged in the +/- 12 V receptacle on APD-100. Check the cable connection from the APD-100 to the measurement instrumentation. Also check that the instrumentation is functioning properly.

Signal Problems	
Symptoms The APD-100 output signal is distorted or lower than expected.	Possible Remedies Possible remedies The input on the measurement instrumentation may be set to 50 OHM mode. THE APD-100 WILL NOT DRIVE A 50 OHM LOAD! Remedy the situation by changing the instrumentation input to high-impedance mode. The APD-100 detector diode may be in saturation, caused by a light source that is too strong. Reduce the gain or use neutral density filters or other means to reduce the light intensity. See the 'output voltage at saturation' column of Table A.1 on page 13 , to make sure the voltage is not exceeded for the model being used. Check that the APD-100 Entrance Aperture is unobstructed and that the light source or beam is striking the center of the detector diode.

A

Specifications

APD-100 General

Model Number	APD-100, Hinds Instruments PN: 020-2651-025-R
Dimension	4 L x 3 W x 1.41 H (in)
Weight	11.7 ounces (APD-100 only)
Shipping weight	4 lbs (includes APD-100, power supply, mounting post and packaging.
Mounting Post Hole Thread Size	¼-20 (in)

APD-100 Input / Output Specifications

Power	+ 12VDC, +/- 0.5V - 12VDC, +/- 0.5V
Output Offset Correction Range	+/- 30mVDC
Signal Output	Table A.1 below shows output characteristics for each APD-100 model

Model	Type	Spectral Range ⁽¹⁾ (nm)	Peak Sensitivity Wavelength, λ	Photodiode Diameter	Effective Active Area	NEP at Response Peak	Frequency Bandwidth, 3dB
001	Si APD	200 to 1000	620 nm	5 mm	19.6 mm ²	1 pW/ $\sqrt{\text{Hz}}$	DC to 450 kHz
Model	Output Voltage at Saturation		Photoelectric Sensitivity, V/W		Maximum Input Light Level, μW	Minimum Input Light Level, nW	Minimum Detection Limit
	Min Gain	Max Gain	Min Gain, $\lambda = 620 \text{ nm}$	Max Gain, $\lambda = 620 \text{ nm}$	Min Gain, $\lambda = 620 \text{ nm}$	Max Gain, $\lambda = 620 \text{ nm}$	Max Gain, $\lambda = 620 \text{ nm}$
001	1.34	8.5V	0.04×10^6	2×10^6	250	90	2 nW r.m.s.

Table A.1: APD-100 Detection and Output Characteristics per APD-100 Model.

(1) See graph of Spectral Response.

■ Spectral response

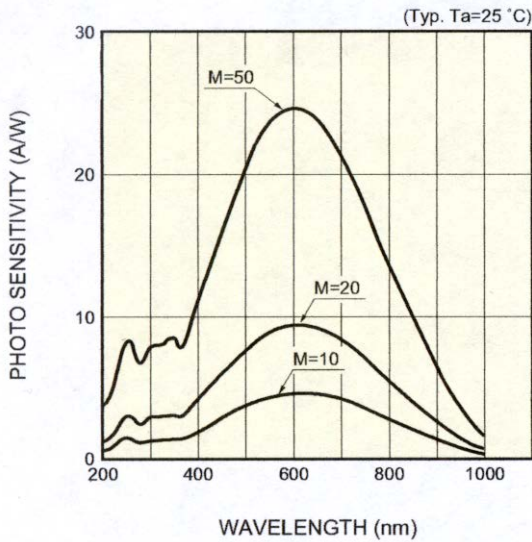

APD-100 Environmental

Operating Temperature	-10 to 50 degrees C
Storage Temperature	-20 to 70 degrees C

APD-100 Approvals

CE
RoHS Compliant

Desktop Power Supply, General

Model Number	028-0000-068-R
Dimensions	4.25 L x 2.64 W x 1.42 H (inches)
Weight	12.7 ounces (excluding cord).

Desktop Power Supply, Input/Output Specifications

Input	100 – 250 VAC, 47 – 63 Hz
Output	+12VDC @ 1A, +/- 0.5V -12VDC @ 0.5V, +/- 0.5V

Desktop Power Supply - Environmental

Operating Temperature	0 to 40 degrees C
Storage Temperature	-30 to 85 degrees C

Desktop Power Supply Approvals

CE

RoHS Compliant

B

User Support Information

Hinds Instruments, Inc. makes every attempt to ensure that the APD-100 Avalanche Photodiode Detector is a product of superior quality and workmanship. Our service personnel are available to assist you from 8:30 a.m. to 3:30 p.m. Pacific time. You may contact our Service Department at 503.690.2000 (Voice), 503.690.3000 (Fax), or service@hindsinstruments.com.

This section consists of the following items:

- A. One-Year Limited Warranty. Please read this information carefully.
- B. Return for Repair Procedure: This procedure is for your convenience in the event you must return your detector/preamplifier for repair. Follow the packing instructions carefully to protect your instrument in transit.

Limited Warranty

Hinds Instruments, Inc. (Hinds) warrants the APD-100 Avalanche Photodiode Detector to be free from defects in materials and/or workmanship when operated in accordance with the manufacturer's operating instructions for one (1) year from the date of purchase, subject to the provisions contained herein. Hinds' warranty shall extend to the original purchaser only and shall be limited to factory repair or replacement of defective parts.

Exclusions

This warranty does not cover normal maintenance, damage resulting from improper user or repair, or abuse by the user. This warranty extends only to repair or replacement, and shall in no event extend to consequential damages. In the event of user repair or replacement, this warranty shall cover neither the advisability of the repair undertaken, nor the sufficiency of the repair itself.

THIS DOCUMENT REFLECTS THE ENTIRE AND EXCLUSIVE UNDERSTANDING OF ALL THE PARTIES, AND EXCEPT AS OTHERWISE PROVIDED HEREIN, ALL OTHER WARRANTIES, EXPRESS OR IMPLIED, PARTICULARLY THE WARRANTIES OF MERCHANTABILITY AND/OR FITNESS FOR A PARTICULAR PURPOSE, ARE EXCLUDED.

This warranty gives you specific legal rights, and you may also have other rights which vary from state to state.

Return for Repair Procedure

In the event of defects for damage to your unit, first call the factory Service Department. Our hours are 8:30 a.m. to 3:30 p.m. Pacific Time, Monday through Friday. You can contact our Service Department at 503.690.2000 (Voice), 503.690.3000 (Fax), or service@hindsinstruments.com.

If factory service is required, return your detector/preamplifier as follows:

Packing

- wrap unit in plastic bag first
- pack in original shipping carton or a sturdy oversized carton
- used plenty of packing material

Include

- Packing List and RMA number emailed to you from the Service Department
- a brief description of the problem with all known symptoms
- your daytime phone number and email address
- your return shipping address (UPS/FedEx will not deliver to a post office box)

Shipping

- send freight prepaid (UPS/FedEx 2nd Day Air recommended)
- insurance recommended (Service Personnel will provide the replacement value of the item(s) being shipped)
- COD shipments will not be accepted

Send to:

Service Department
Hinds Instruments, Inc.
7245 NW Evergreen Pkwy
Hillsboro, OR 97124-5850 USA

If your unit is under warranty, after repair or replacement has been completed, it will be returned by a carrier and method chosen by Hinds Instruments, Inc. to any destination within the continental United States. If you desire some specific form of conveyance or if you are beyond these borders, then you must bear the additional cost of return shipment.

If your unit is not under warranty, we will call you with an estimate of the charges. If approved, your repaired unit will be returned after all charges, including parts, labor, and return shipping and handling, have been paid in full. If not approved, your unit will be returned as is via UPS COD for the amount of the UPS COD freight charges.

Index

A		S	
APD-100		sample set-up.....	7
accessories	1	SCU-100.....	1
front plate	4	signal amplification	1
Front Plate.....	3	signal amplification	1
operation	9	specifications	
overview	1	APD-100 approvals.....	14
rear plate	3	APD-100 environmental.....	14
sample set-up.....	7	APD-100 general	13
Side Plate.....	4	APD-100 input/output	13
Top Plate.....	5	desktop power supply	14
troubleshooting.....	11		
		T	
C		troubleshooting.....	11
connecting the APD-100.....	7	power problems	11
		signal problems.....	12
P			
power supply specifications		W	
approvals.....	15	warranties	
environmental.....	15	document.....	ii
input/output	14	exclusions	17
		limited	17
R			
return for repair	18		



HINDS INSTRUMENTS, INC
7245 NW EVERGREEN PKWY
HILLSBORO, OR 97124 USA
PHONE: 503/690.2000
FAX: 503/690.3000
TOLL FREE: 1.800/688.4463
EMAIL: sales@hindsinstruments.com
www.hindsinstruments.com

COPYRIGHT ©2007, 2013
HINDS INSTRUMENTS, INC All Rights Reserved
MANUFACTURED IN USA UNDER PATENTS &
PATENTS PENDING
PRINTED IN USA