

REV.	DESCRIPTION	BY	DATE
0	INITIAL CONTROL.	cmansfield	7/19/2017

DIMENSIONS: INCHES [mm]

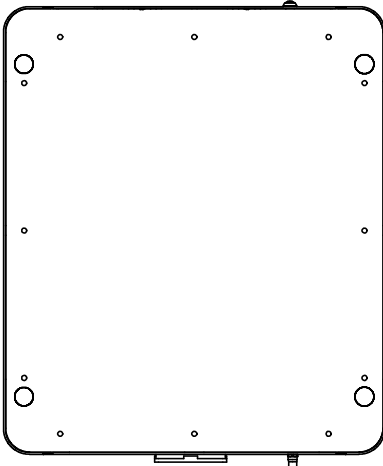
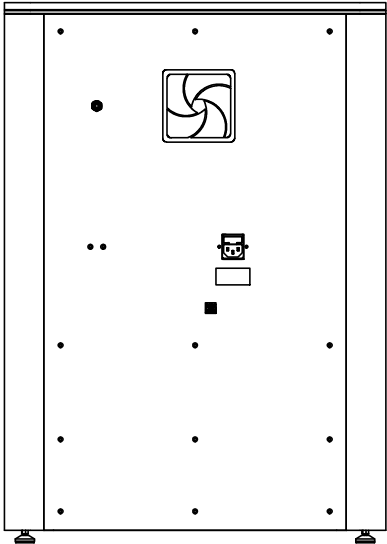
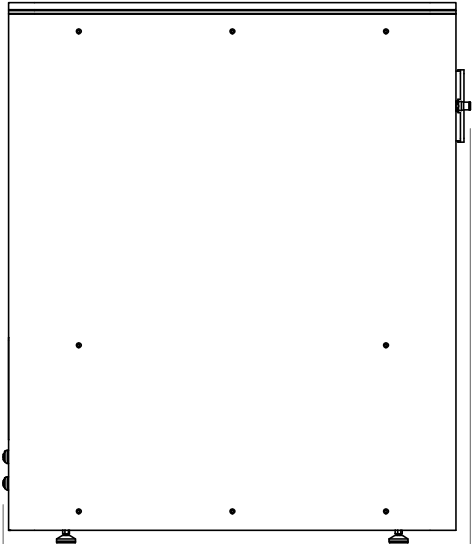
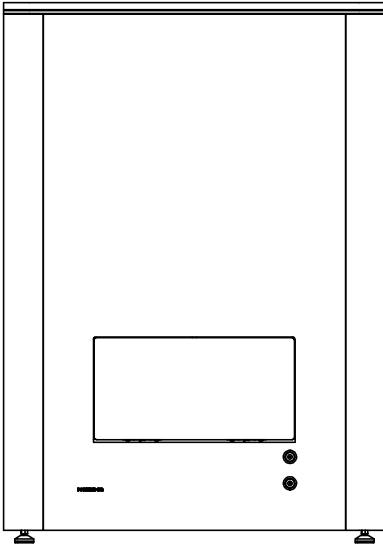
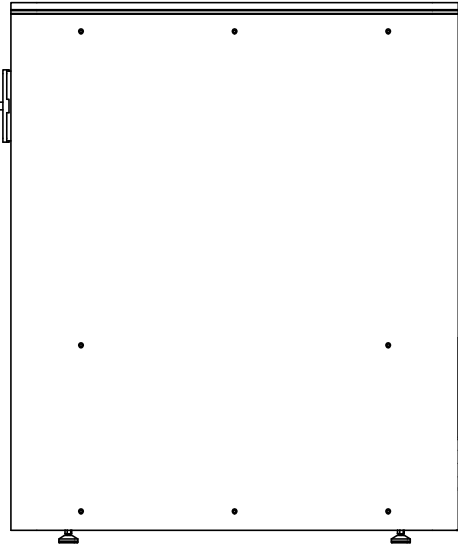
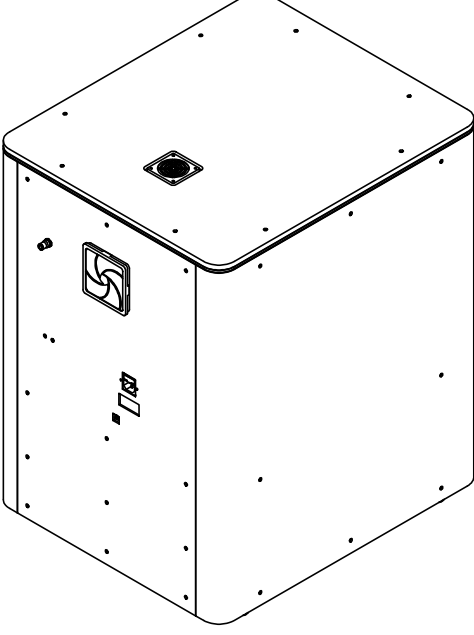
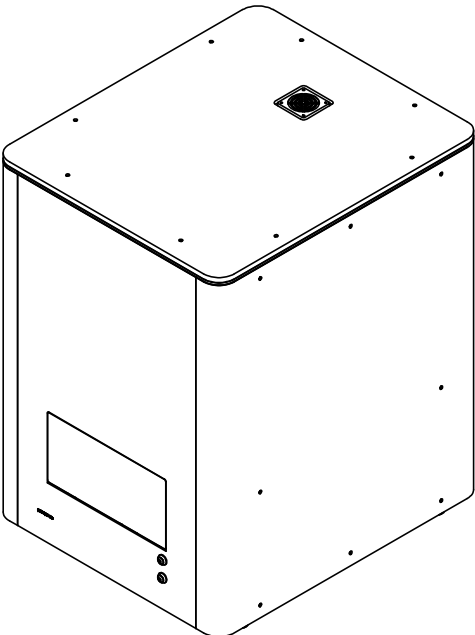
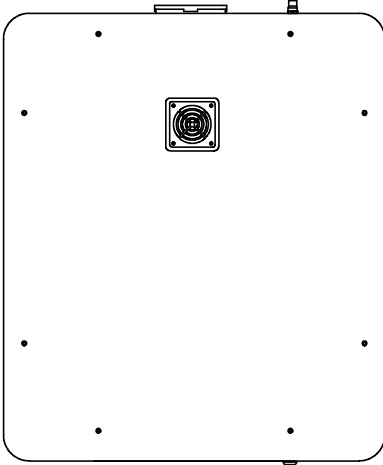

WEIGHT = 208 lbs. [94kg]

UNSPECIFIED LIMITS DIMENSIONS ARE IN INCHES	
FRACTIONS	± 1/32
DECIMALS	.XX ± .010 .XXX ± .005
HOLE DIA's	.XX ± .010 .XXX ± .003 .XXX ± .001
ANGLES	± 0° 30'
BENDS	± 2°
PERPENDICULARITY	.003/INCH
CONCENTRICITY	.003 TIR
STRAIGHTNESS &/OR FLATNESS: .005/INCH	
THREADS: - CLASS 2A INTERNAL - CLASS 2B	
UNMARKED ANGLES BENDS & INTERSECTIONS: 90°	
MACHINED SURFACES: 63 OR BETTER	
REMOVE ALL BURRS & SHARP CORNERS	
SAMPLES MUST BE APPROVED BY ENGINEERING DEPARTMENT PRIOR TO STARTING PRODUCTION	
THIS DRAWING IS THE PROPERTY OF HINDS INSTRUMENTS INC. ALL RIGHTS RESERVED.	

DO NOT SCALE DRAWING	
DATE PRINTED:	
APPROVALS	DATE
DRAWN cmansfield	7/19/17
CHECKED	
MATERIAL	
FINISH	

HINDS Instruments, Inc.
7245 NE Evergreen Pkwy
Hillsboro, OR 97124
PHONE (503) 690-2000 FAX (503) 690-3000

**CD Microplate
Reader - Overall
Dimensions**

SIZE B	FSCM NO.	DWG. NO. 07192017-OD	REV. 0
SCALE 1:10	RELEASE DATE:	SHEET 1 OF 1	