

Exicor 600HD:

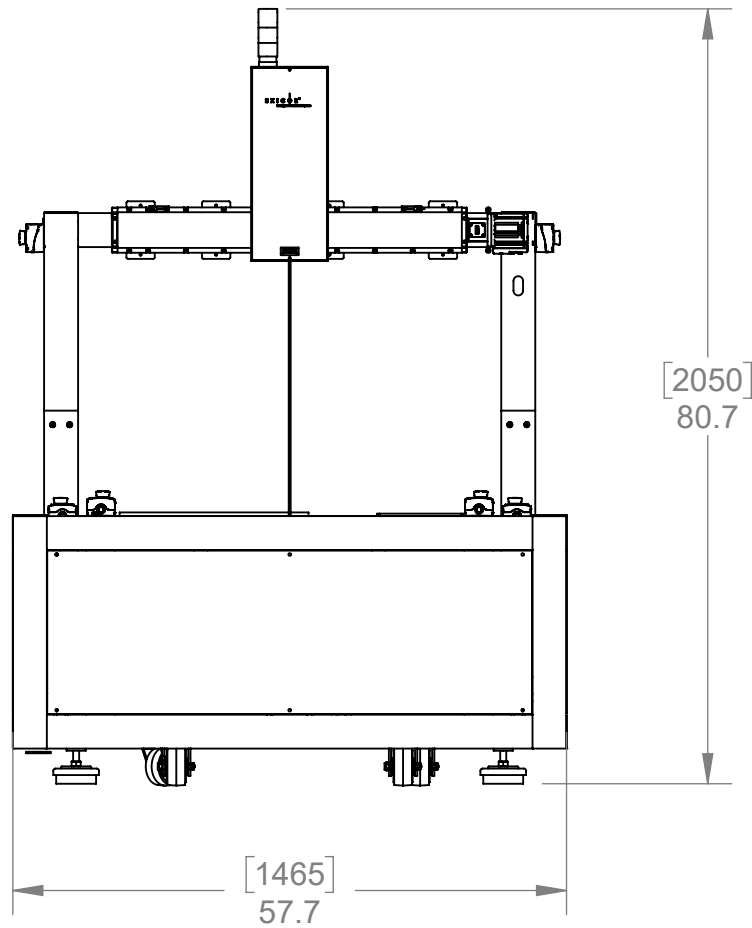

REV.	DESCRIPTION	BY	DATE
0	INITIAL CONTROL.	cmansfield	3/12/2024

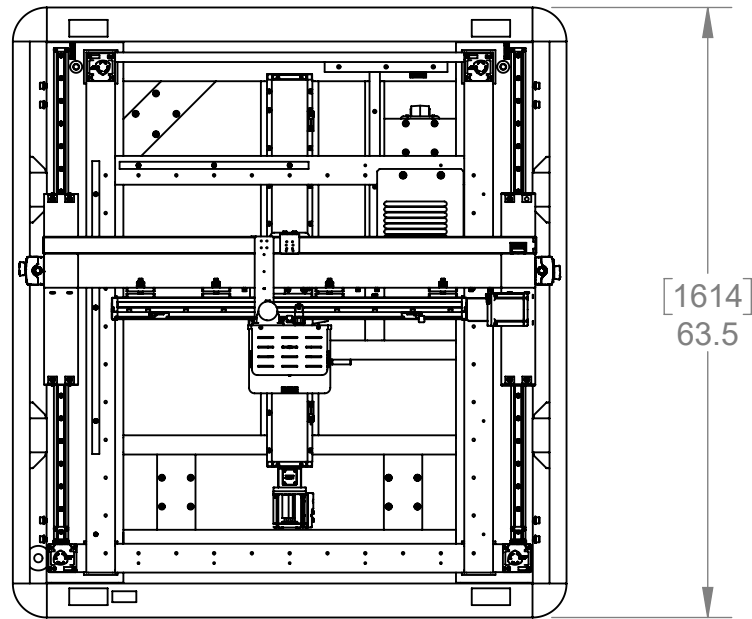
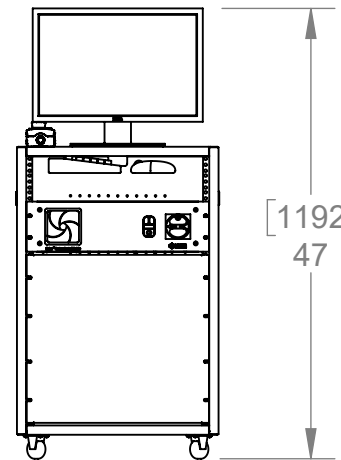
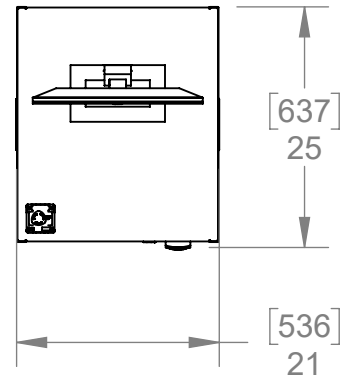
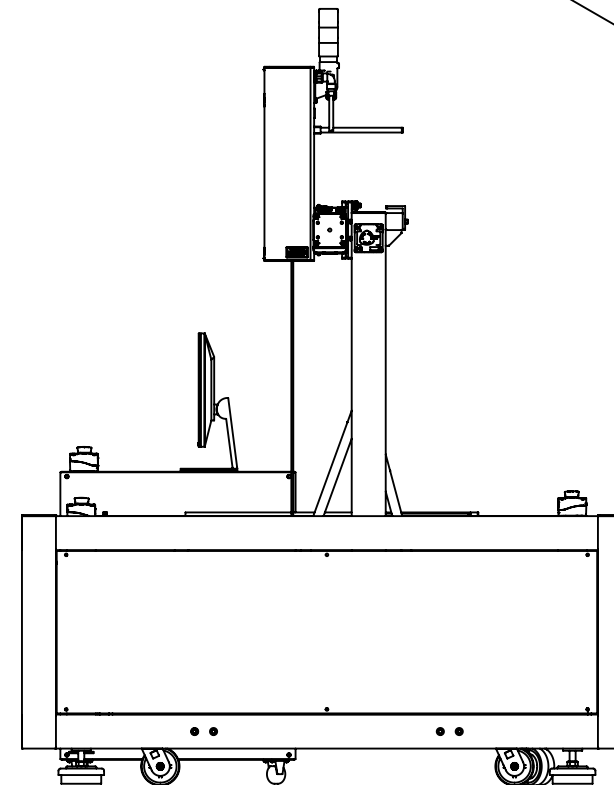
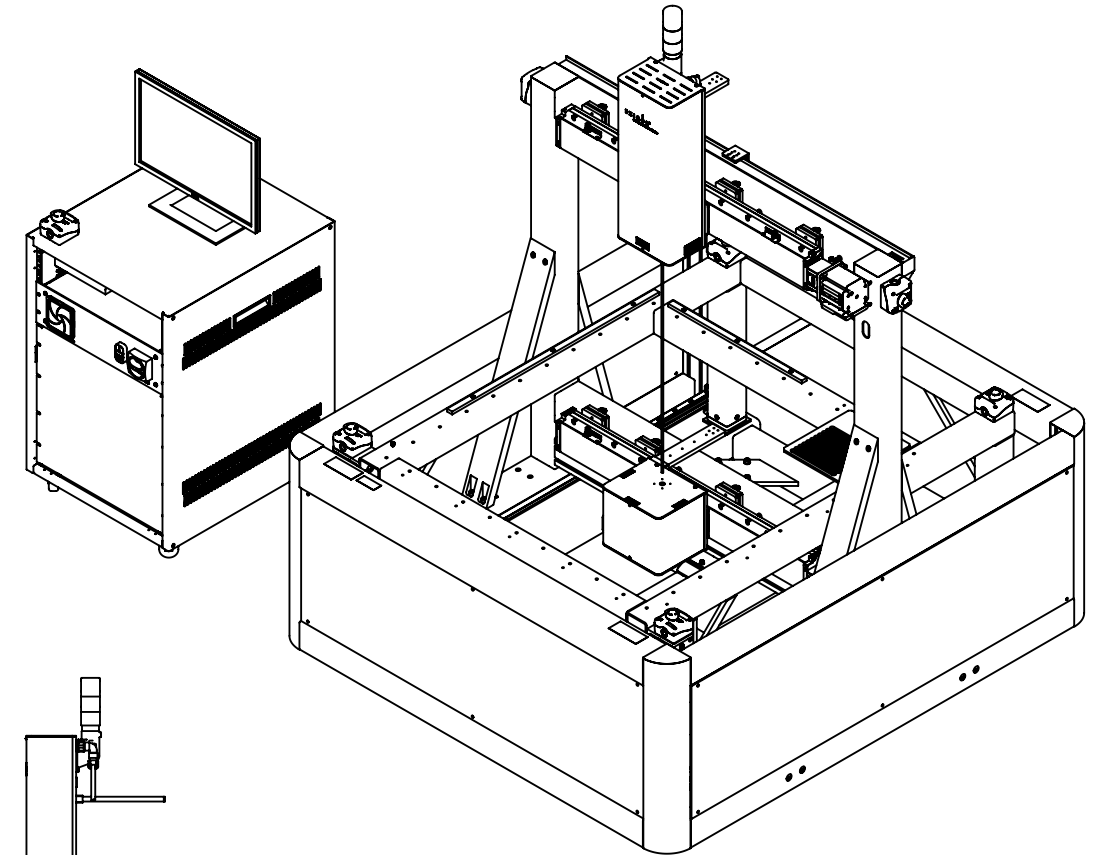

Dimensions: inch[mm]

UNSPECIFIED LIMITS DIMENSIONS ARE IN INCHES		DO NOT SCALE DRAWING		HINDS Instruments, Inc. <small>7245 NE Evergreen Pkwy, Suite 150 Hillsboro, OR 97124 PHONE (503) 690-2000 FAX (503) 690-3000</small>
FRACTIONS ± 1/32	STRAIGHTNESS &/OR FLATNESS: .005/INCH	DATE PRINTED:		
DECIMALS .XX ± .010 .XXX ± .005	THREADS: EXTERNAL - CLASS 2A INTERNAL - CLASS 2B	APPROVALS	DATE	
HOLE DIA's .XX ± .010 .XXX ± .003 .XXX ± .001	UNMARKED ANGLES, BENDS & INTERSECTIONS: 90°	DRAWN cmansfield	3/12/24	
ANGLES ± 0° 30'	MACHINED SURFACES: 63 OR BETTER	CHECKED		
BENDS ± 2°	REMOVE ALL BURRS & SHARP CORNERS	MATERIAL		
PERPENDICULARITY .003/INCH		FINISH		
CONCENTRICITY .003 TIR				
SAMPLES MUST BE APPROVED BY ENGINEERING DEPARTMENT PRIOR TO STARTING PRODUCTION		SIZE B	FSCM NO.	DWG. NO. 010-0000-124
THIS DRAWING IS THE PROPERTY OF HINDS INSTRUMENTS INC. ALL RIGHTS RESERVED.		SCALE 1:20	RELEASE DATE:	REV. 0
		SHEET 1 OF 2		

REV.	DESCRIPTION	BY	DATE
-	See Sheet1	-	-

Excior 600HD: Gantry Max Back Loading Position

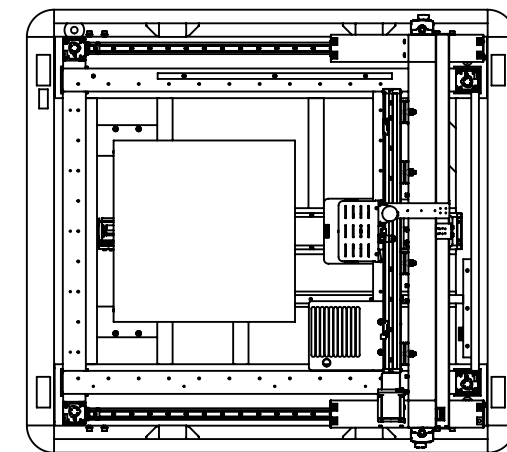
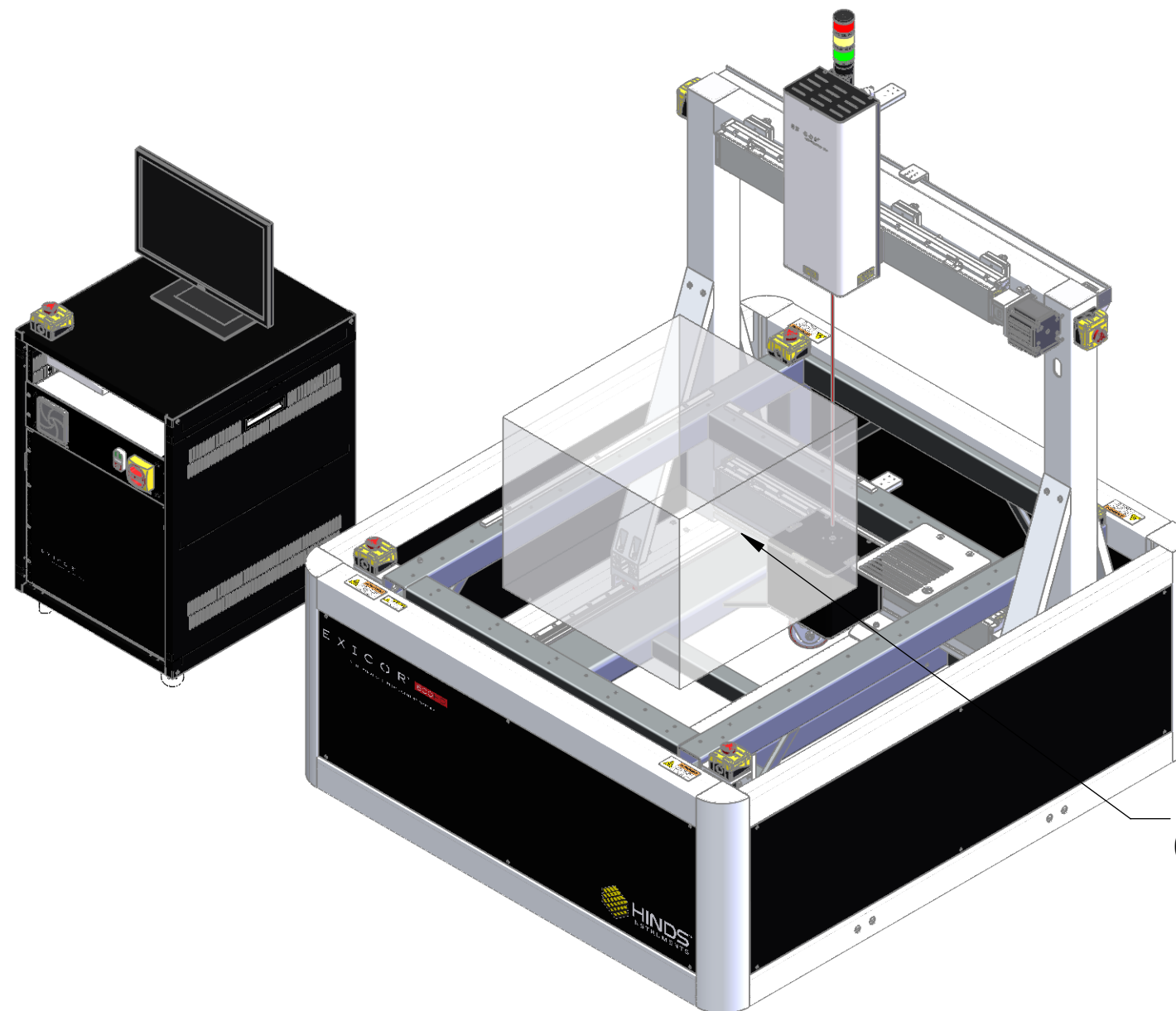

MAXIMUM GANTRY BACK
 [1031]
 40.6

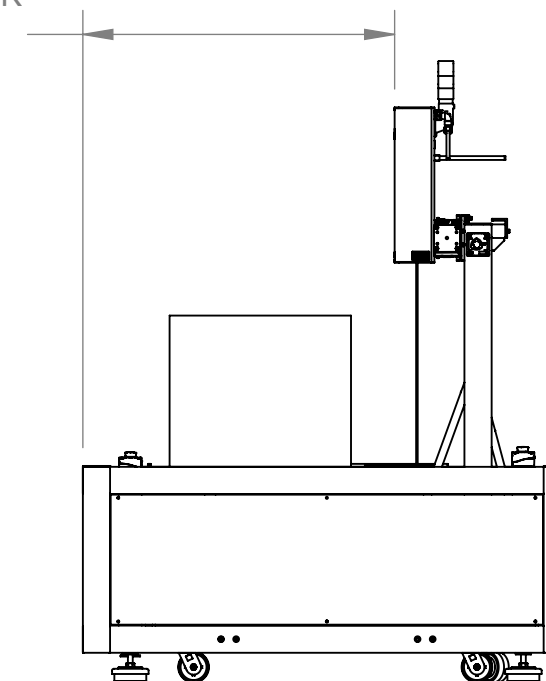

Max Sample Size
 600mm x 600mm x 500mm

CONFIDENTIAL

UNSPECIFIED LIMITS DIMENSIONS ARE IN INCHES		DO NOT SCALE DRAWING		 HINDS Instruments, Inc. <small>7245 NE Evergreen Pkwy, Suite 150 Hillsboro, OR 97124 PHONE (503) 690-2000 FAX (503) 690-3000</small>		
FRACTIONS ± 1/32	STRAIGHTNESS &/OR FLATNESS: .005/INCH	DATE PRINTED:		<h2>Excior 600HD</h2>		
DECIMALS .XX ± .010 .XXX ± .005	THREADS: EXTERNAL - CLASS 2A INTERNAL - CLASS 2B	APPROVALS				DATE
HOLE DIA's .XX ± .010 .XXX ± .003 .XXX ± .001	UNMARKED ANGLES, BENDS & INTERSECTIONS: 90°	DRAWN				3/12/24
ANGLES ± 0° 30'	MACHINED SURFACES: 63 OR BETTER	CHECKED				
BENDS ± 2°	REMOVE ALL BURRS & SHARP CORNERS	MATERIAL		SCALE 1:25		
PERPENDICULARITY .003/INCH		FINISH		FSCM NO.		
CONCENTRICITY .003 TIR				DWG. NO. 010-0000-124		
SAMPLES MUST BE APPROVED BY ENGINEERING DEPARTMENT PRIOR TO STARTING PRODUCTION				REV. 0		
THIS DRAWING IS THE PROPERTY OF HINDS INSTRUMENTS INC. ALL RIGHTS RESERVED.				RELEASE DATE:		
				SHEET 2 OF 2		