

REV.	DESCRIPTION	BY	DATE
0	INITIAL CONTROL	cmansfield	3/14/2012

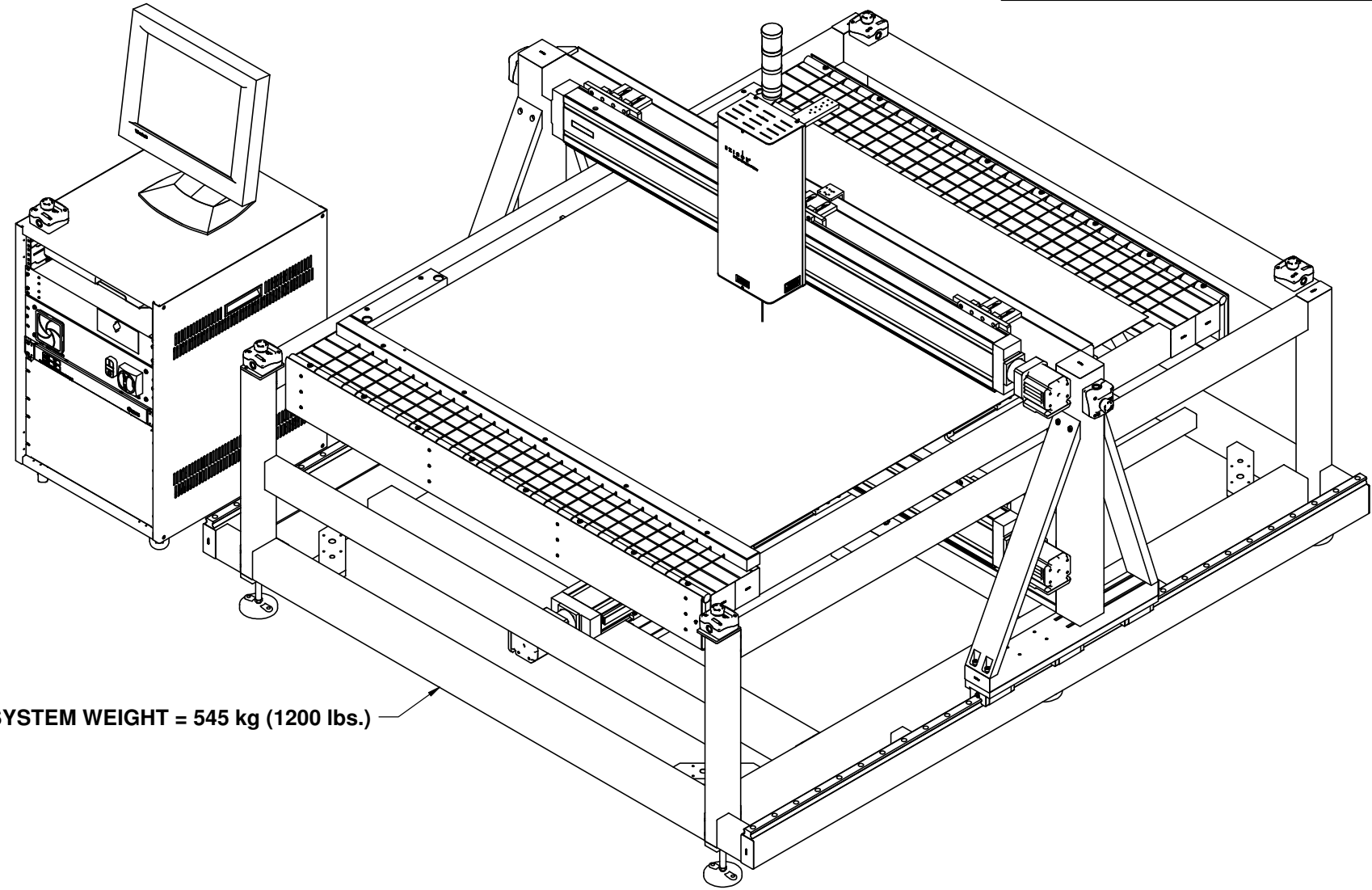

DIMENSIONS: mm

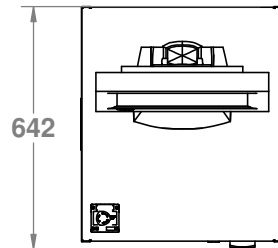
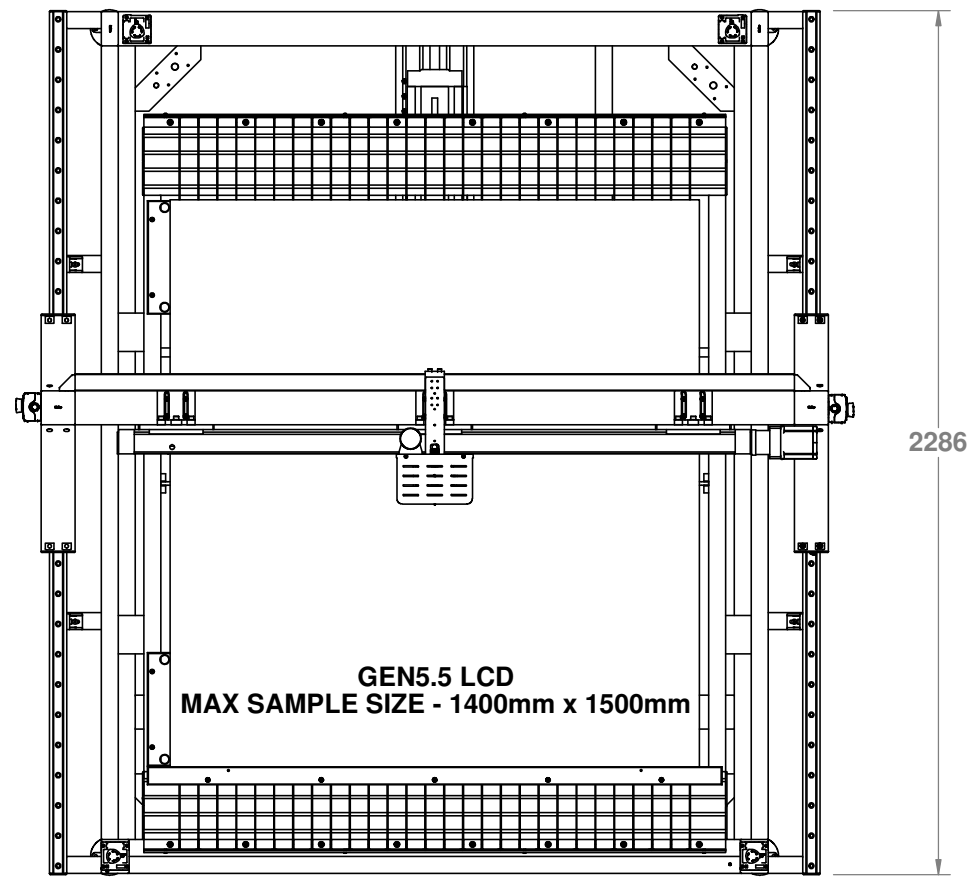
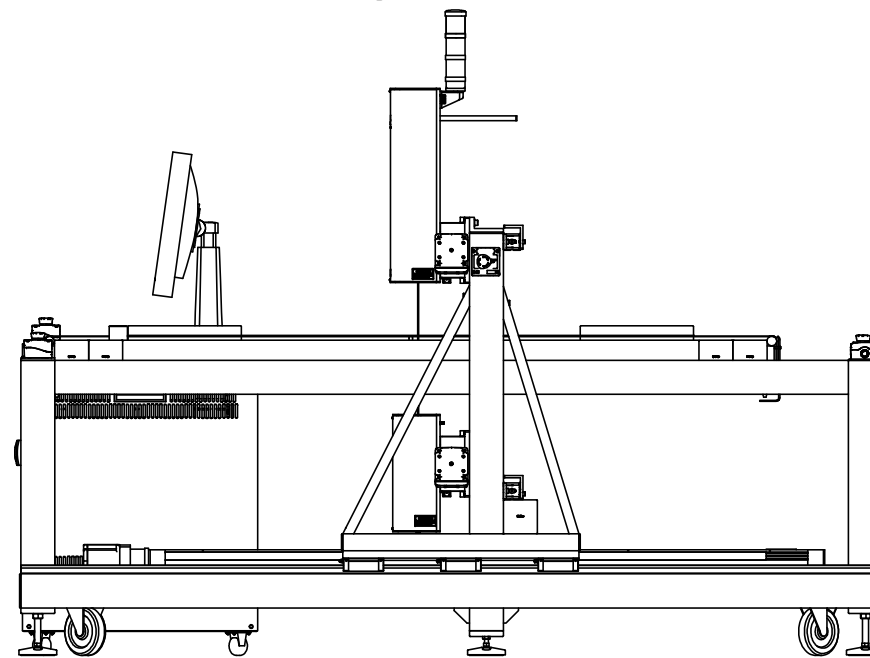
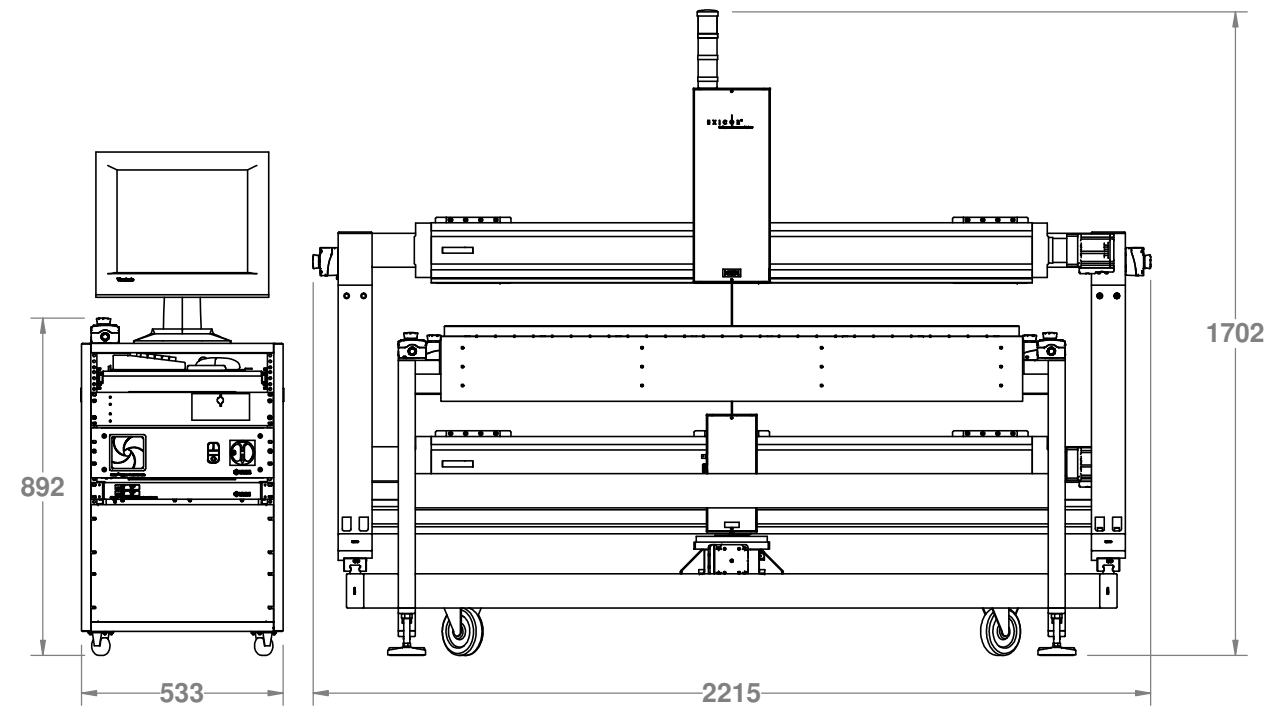

UNSPECIFIED LIMITS DIMENSIONS ARE IN INCHES		DO NOT SCALE DRAWING		HINDS Instruments, Inc.	
FRACTIONS	+ 1/32	STRAIGHTNESS AND FLATNESS	0.005 INCH	DATE PRINTED:	
DECIMALS	XX + 0.01	THREADS	INTERNAL - CLASS 2A	APPROVALS	DATE
HOLE DIA.	XX + 0.01	SHARPENED ANGLES	BENCH & INTERSECTIONS: 90°	cmansfield	3/14/12
ANGLES	+ 0'30	MACHINED SURFACES:	32 OR BETTER	CHECKED	
BENDS	+ 2'	REMOVE ALL BURRS & SHARP CORNERS		MATERIAL	
PERPENDICULARITY	0.001 INCH			FINISH	
CONCENTRICITY	0.001 INCH			SCALE	1:10
SAMPLES MUST BE APPROVED BY ENGINEERING DEPARTMENT PRIOR TO STARTING PRODUCTION					

REV.	DESCRIPTION	BY	DATE
0	INITIAL CONTROL	cmansfield	3/14/2012

USE	FORM NO.	DWG. NO.	REV.
D		010-0000-068-OD	0
SCALE	1:10	RELEASE DATE:	SHEET 1 OF 1

**Excior GEN5.5 LCD,
Overall Dimensions**