

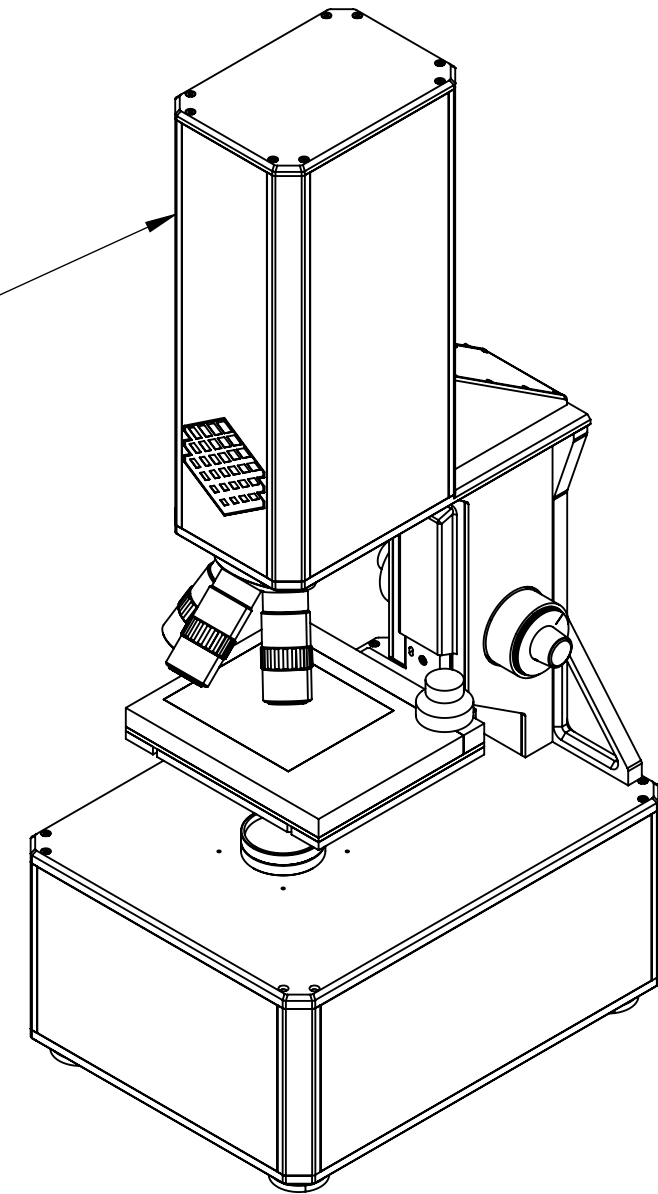

REV.	DESCRIPTION	BY	DATE
0	INITIAL CONTROL.	cmansfield	6/25/2021

DIMENSIONS: INCH[mm]

WEIGHT = 36 lbs. [16 kg]

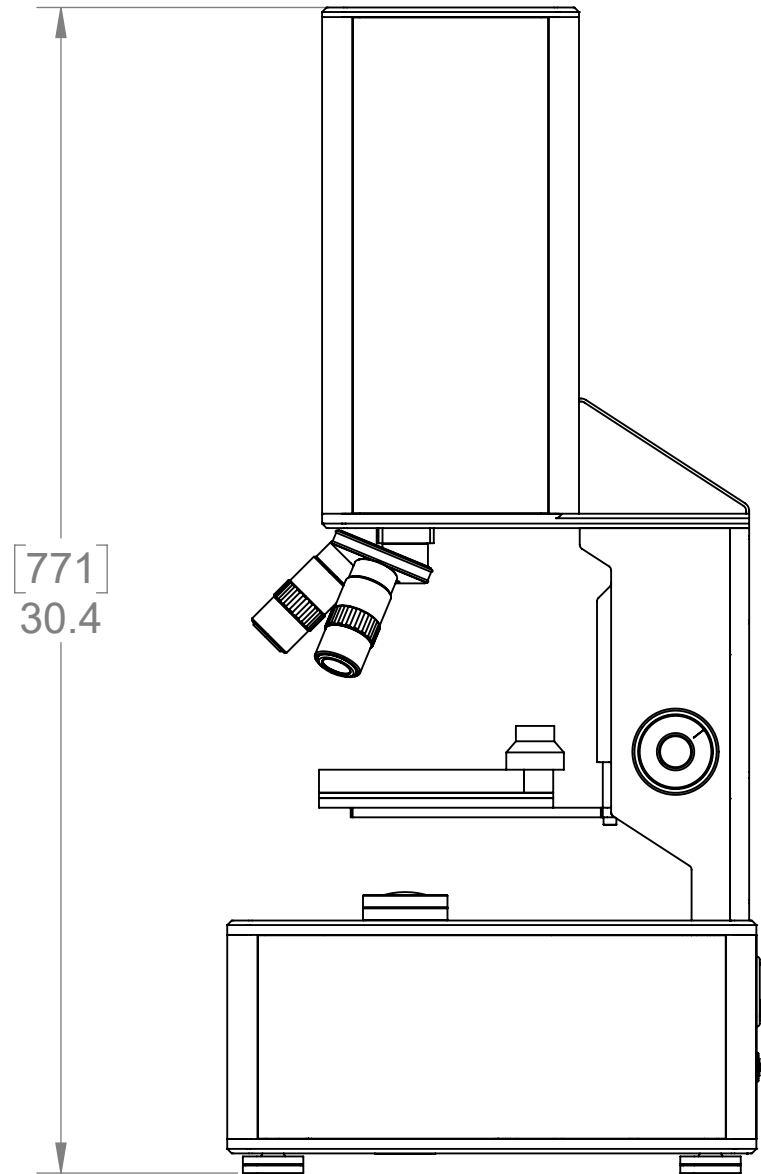
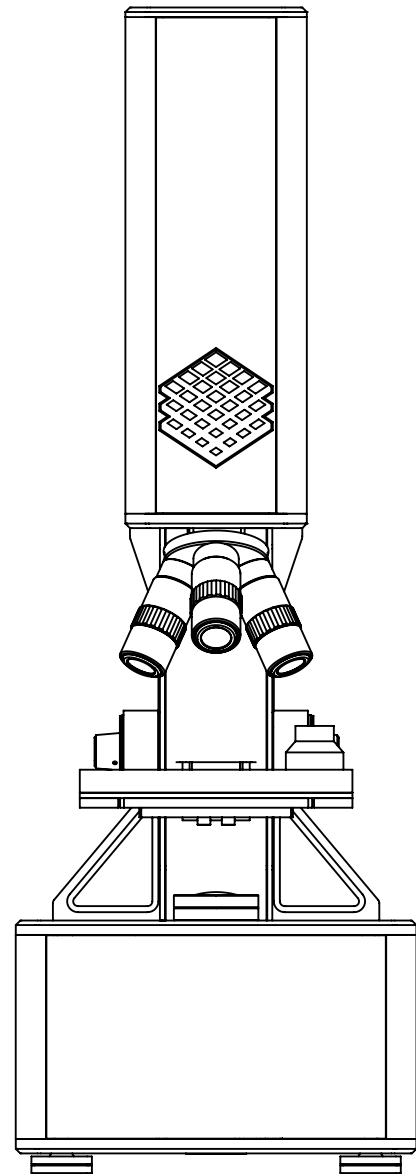
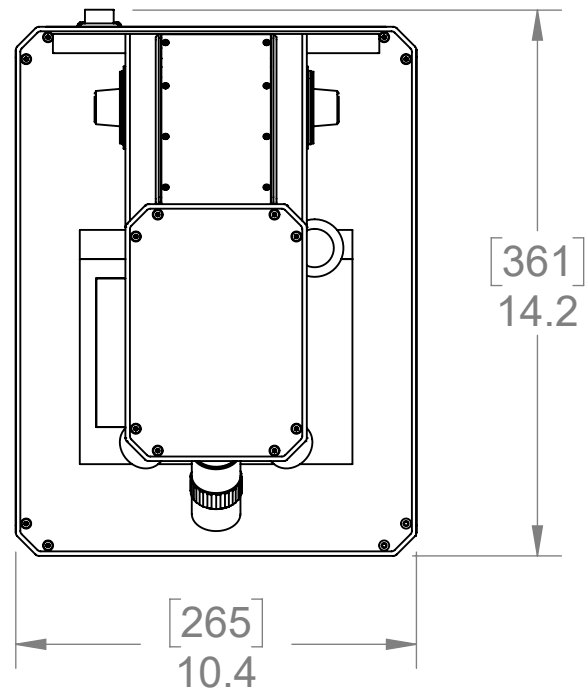

[771]  
30.4

UNSPECIFIED LIMITS DIMENSIONS ARE IN INCHES		DO NOT SCALE DRAWING		HINDS <sup>®</sup> Instruments, Inc. 7245 NE Evergreen Pkwy, Suite 150 Hillsboro, OR 97124 PHONE (503) 690-2000 FAX (503) 690-3000	
FRACTIONS	± 1/32	DATE PRINTED:		<b>Exicor Micro-Imager 2.0</b>	
DECIMALS	.XX ± .010 .XXX ± .005	APPROVALS			
HOLE DIA's	.XX ± .010 .XXX ± .003 ± 0° 30'	DRAWN		6/25/21	SIZE B FSCM NO. DWG. NO. 010-0000-077-R REV. 0 SCALE 1:5 RELEASE DATE: SHEET 1 OF 1
ANGLES	± 2°	CHECKED			
BENDS	± 2°	MATERIAL			
PERPENDICULARITY	.003/INCH	FINISH			
CONCENTRICITY	.003 TIR	SAMPLES MUST BE APPROVED BY ENGINEERING DEPARTMENT PRIOR TO STARTING PRODUCTION THIS DRAWING IS THE PROPERTY OF HINDS INSTRUMENTS INC. ALL RIGHTS RESERVED.			